

SERVO-CONTROLLED 3-WAY VACUUM SOLENOID VALVES

The 3-way vacuum solenoid valves in this series are 2-position valves with pneumatically servo-controlled conical shutters.

They can normally be used either open or closed.

They are composed of an anodised aluminium body, two vulkollan® shutters assembled onto a stainless steel stem, a membrane for servo-control made with special compounds and a thrust spring for the shutter return; an actuator activated by an electric coil managed the compressed air supply.

These valves allow reducing frictions and internal dynamic stresses to the minimum. the result being a high response speed and a guarantee of long lasting duration.

The standard electric coil is fully plasticised with synthetic resin, tight execution, insulation class F (up to 155 °C) compliant with VDE standards, with 6.3 mm 3-terminal electrical connections in compliance with EN 175301-803 (ex DIN 43650). Protection degree IP 54; IP 65 for inserted connector.

Allowed tolerance on the voltage nominal value: ±10%.

Max. absorption: 16.5 V.A. in c.a. e 16 W in c.c.

The electric coil can be rotated by 360°. The connector can be rotated by 180° on the coil and can be supplied, upon request, with Led lights, anti-interference circuit and/or with protection devices against overvoltage and polarity reversal.

3-way vacuum solenoid valves are usually used for intercepting vacuum on feeders and cup stackers, robots, sheet feeders, sack openers and in all those cases where a quick response is needed between suction and the air inlet into the circuit, for a quick restoration of the atmospheric pressure.

They can be supplied upon request with an SM device for manually opening and closing the solenoid valves already installed.

Technical features

Working pressure: from 0.5 to 3000 mbar abs.

Servo-control pressure: see table

Temperature of the sucked fluid: from -5 to +60 °C

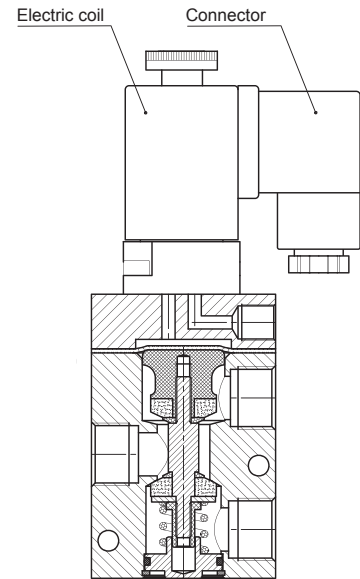
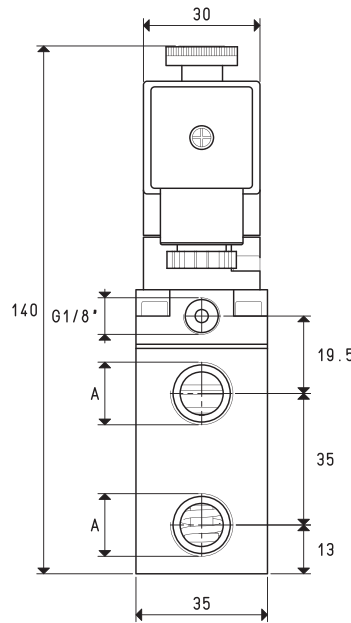
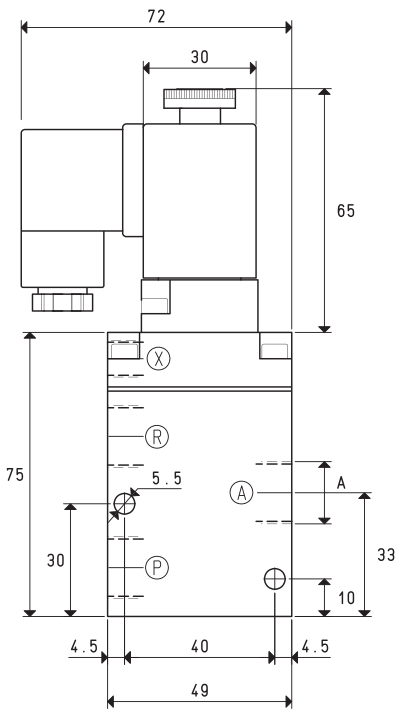

NC

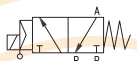

X = Compressed air supply
P = Pump
A = Service
R = Passage

NO



X = Compressed air supply
P = Passage
A = Service
R = Pump

Art.	A	Max. capacity cum/h	Vacuum level mbar abs.		Reaction time msec		Ø orifice	Passage section mm²	Servo-control pressure *bar (g)	Weight Kg
			min	max	exc.	deexc.				
07 01 11	G1/4"	6	1000	0.5	16	27	56.8	8.5	4 ÷ 7	0.56
07 02 11	G3/8"	10	1000	0.5	16	27	103.8	11.5	4 ÷ 7	0.54

Note: The coil and the connectors are not integral part of the solenoid valves, therefore, they must be ordered separately (See solenoid valve accessories).

SERVO-CONTROLLED 3-WAY VACUUM SOLENOID VALVES

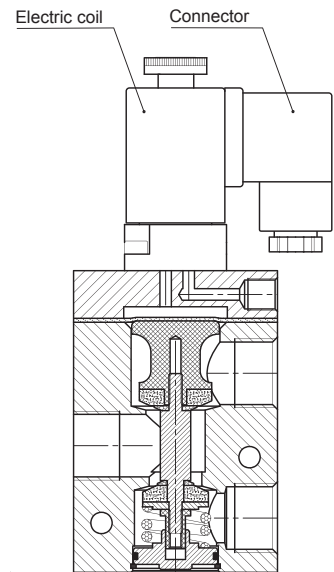
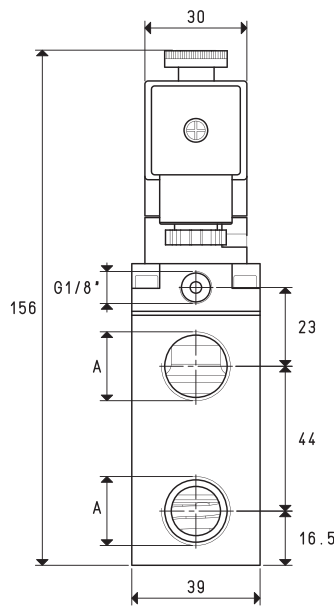
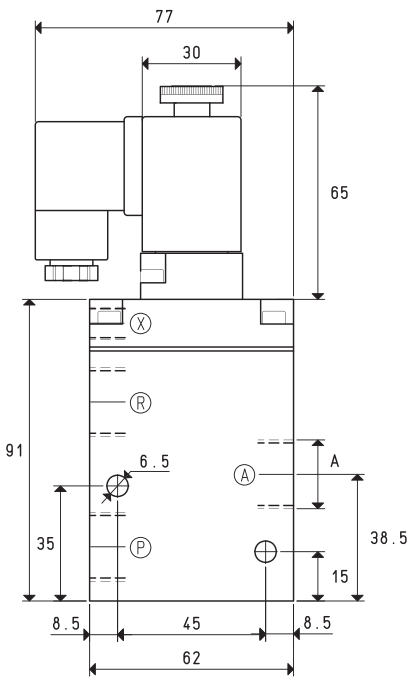

NC

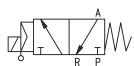

X = Compressed air supply
P = Pump
A = Service
R = Passage

NO

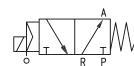

X = Compressed air supply
P = Passage
A = Service
R = Pump

Art.	A Ø	Max. capacity cum/h	Vacuum level mbar abs.		Reaction time msec		Ø orifice	Passage section mm ²	Servo-control pressure *bar (g)	Weight Kg
			min	max	exc.	deexc.				
07 03 11	G1/2"	20	1000	0.5	16	40	15.0	176	6 ÷ 8	0.73

* Add the letters LP to the article for servo-control pressure 4 ÷ 6 bar (g).

Note: The coil and the connectors are not integral part of the solenoid valves, therefore, they must be ordered separately (See solenoid valve accessories).

Conversion ratio: inch = $\frac{\text{mm}}{25.4}$; pounds = $\frac{\text{g}}{453.6}$ = $\frac{\text{Kg}}{0.4536}$

GAS-NPT thread adapters available at page 1.117

SERVO-CONTROLLED 3-WAY VACUUM SOLENOID VALVES

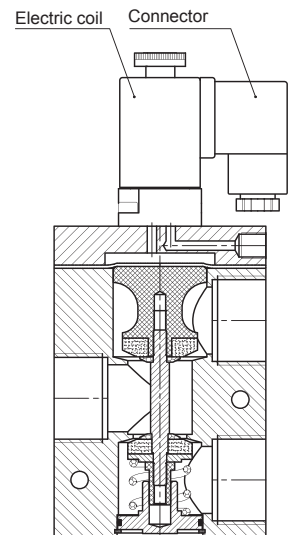
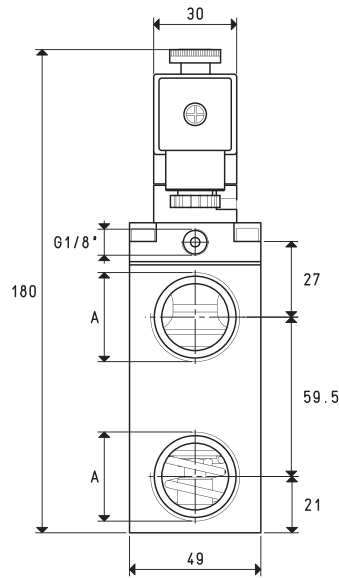
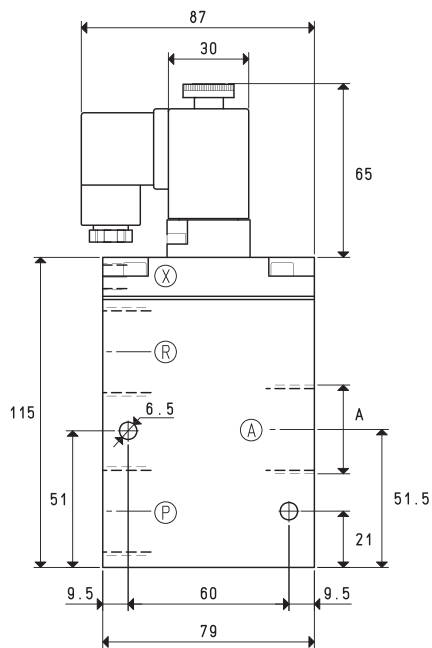

3D drawings available at www.vuototecnica.net

NC

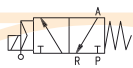

X = Compressed air supply
P = Pump
A = Service
R = Passage

NO

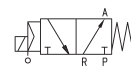

X = Compressed air supply
P = Passage
A = Service
R = Pump

Art.	A Ø	Max. capacity cum/h	Vacuum level mbar abs.		Reaction time msec		Ø orifice	Passage section mm ²	Servo-control pressure *bar (g)	Weight Kg
			min	max	exc.	deexc.				
07 04 11	G3/4"	40	1000	0.5	16	40	20	314	6 ÷ 8	1.25
07 05 11	G1"	90	1000	0.5	18	42	25	490	6 ÷ 8	1.16

* Add the letters LP to the article for servo-control pressure 4 ÷ 6 bar (g).

Note: The coil and the connectors are not integral part of the solenoid valves, therefore, they must be ordered separately (See solenoid valve accessories).

SERVO-CONTROLLED 3-WAY VACUUM SOLENOID VALVES



4

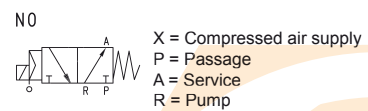
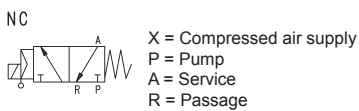
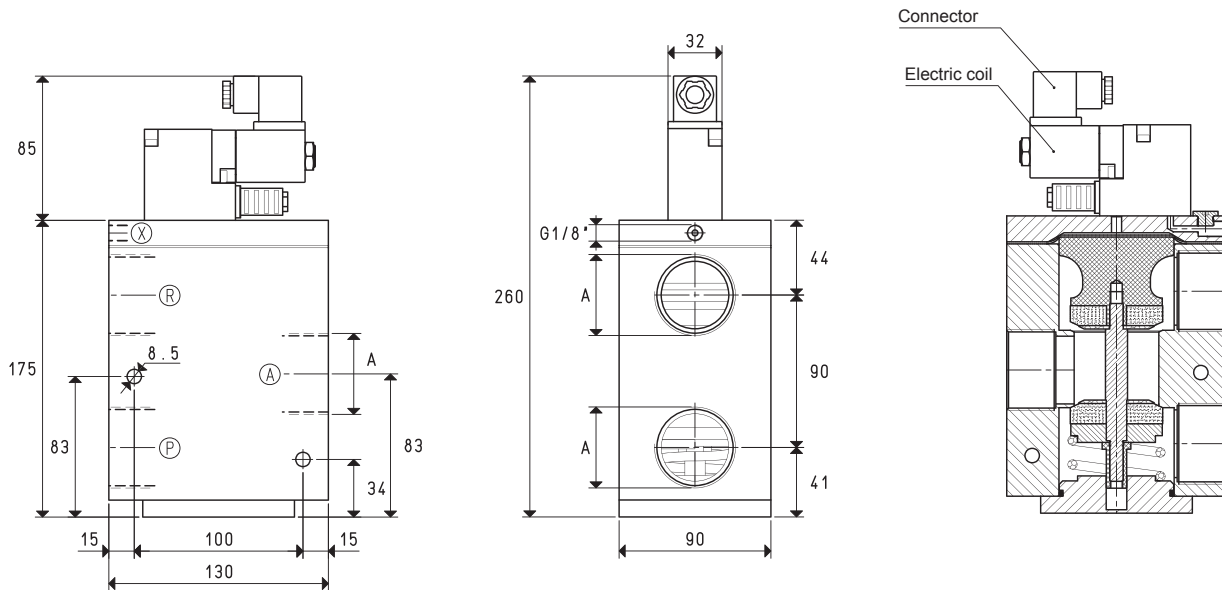

Art.	A	Max. capacity cum/h	Vacuum level mbar abs.		Reaction time msec		Ø orifice	Passage section mm ²	Servo-control pressure *bar (g)	Weight Kg
	Ø		min	max	exc.	deexc.				
07 06 11	G1" 1/2	180	1000	0.5	60	38	40	1256	6 ÷ 8	4.79

* Add the letters LP to the article for servo-control pressure 4 ÷ 6 bar (g).

Note: The coil and the connectors are not integral part of the solenoid valves, therefore, they must be ordered separately (See solenoid valve accessories).

Conversion ratio: inch = $\frac{\text{mm}}{25.4}$; pounds = $\frac{\text{g}}{453.6}$ = $\frac{\text{Kg}}{0.4536}$

GAS-NPT thread adapters available at page 1.117

3D drawings available at www.vuototecnica.net