

MULTI-STAGE VACUUM GENERATORS PVP 40 ÷ 300 M

This new range of multi-stage vacuum generators have been designed to be assembled onto OCTOPUS vacuum systems and represents a true evolution of traditional vane vacuum pumps. They feature state of the art ejectors and boast an excellent ratio between the consumed and the sucked air to the benefit of operative consumption. They also allow adjusting the vacuum level and capacity according to the air supply pressure.

When designing these vacuum generators, our focus was on noise; In fact, they are free of moving parts subject to vibrations and wear and they are perfectly soundproofed, therefore, their operation is particularly silent.

Moreover, their operation being based on Venturi's principle, they do not develop heat.

The light alloys used to make them have allowed a considerable reduction of their weight. A good filtration of the compressed air supply and of the sucked one allows discharging air free from oil vapours, water condensation and impurities and reducing maintenance to a simple regular filtre cleaning.

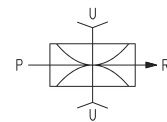
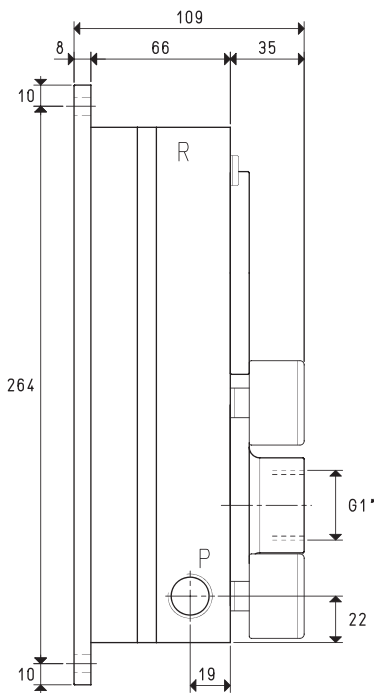
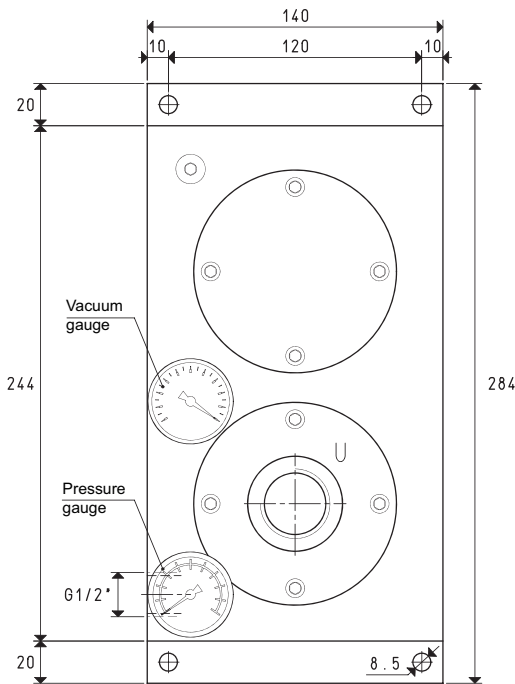

3D drawing available at www.vuototecnica.net

Art.	P=COMPRESSED AIR CONNECTION	R=EXHAUST	U=VACUUM CONNECTION							
			PVP 40 M	PVP 70 M	PVP 100 M	PVP 150 M	PVP 200 M	PVP 250 M	PVP 300 M	
Max. quantity of sucked air	cum/h	36	39	42	65	73	80	88	98	108
Max. vacuum level	-KPa	65	82	90	65	82	90	65	82	90
Final pressure	mbar abs.	350	180	100	350	180	100	350	180	100
Supply pressure	bar (g)	4	5	6	4	5	6	4	5	6
Air consumption	Nl/s	2.3	2.7	3.2	4.9	5.7	6.6	7.2	8.5	9.8
Working temperature	°C			-20 / +80			-20 / +80			-20 / +80
Noise level	dB(A)			67			68			70
Weight	Kg			4.2			4.2			4.2
Spare parts										
Sealing kit e disc valves	art.			00 KIT PVP 40 M			00 KIT PVP 70 M			00 KIT PVP 100 M
Vacuum gauge	art.			09 03 15			09 03 15			09 03 15
Pressure gauge	art.			09 03 25			09 03 25			09 03 25

Note: All the vacuum data indicated in the table are valid at the normal atmospheric pressure of 1013 mbar and are obtained with a constant supply pressure.

By adding the letter R to the article, the generator will be supplied with a built-in check valve (E.g.: PVP 40 MR).

8.68

Conversion ratio: inch = $\frac{mm}{25.4}$; pounds = $\frac{g}{453.6} = \frac{Kg}{0.4536}$

GAS-NPT thread adapters available at page 1.117



8



MULTI-STAGE VACUUM GENERATORS PVP 40 M, 70 M and 100 M

Air capacity (NI/s) at different vacuum levels (-Kpa)

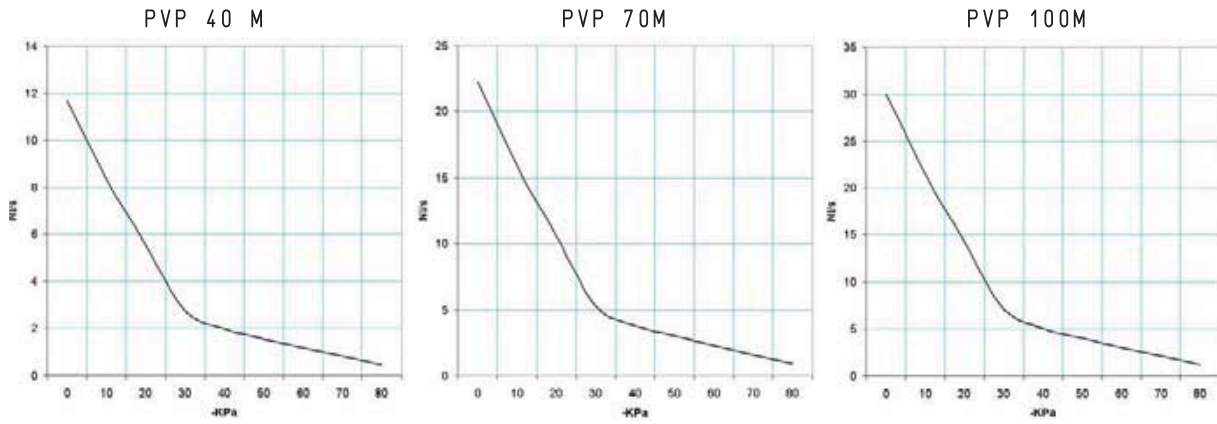

Generator art.	Supply press. bar (g)	Air consumption NI/s	Air capacity (NI/s) at different vacuum levels (-KPa)										Max. vacuum level -KPa
			0	10	20	30	40	50	60	70	80	90	
PVP 40 M	6.0	3.2	11.66	8.32	5.55	2.77	1.98	1.58	1.19	0.83	0.47	90	
PVP 70 M	6.0	6.6	22.22	15.87	10.58	5.29	3.77	3.02	2.27	1.58	0.90	90	
PVP 100 M	6.0	9.8	30.00	21.42	14.28	7.14	5.10	4.08	3.06	2.14	1.22	90	

Evacuation time (ms/l=s/m³) at different vacuum levels (-Kpa)

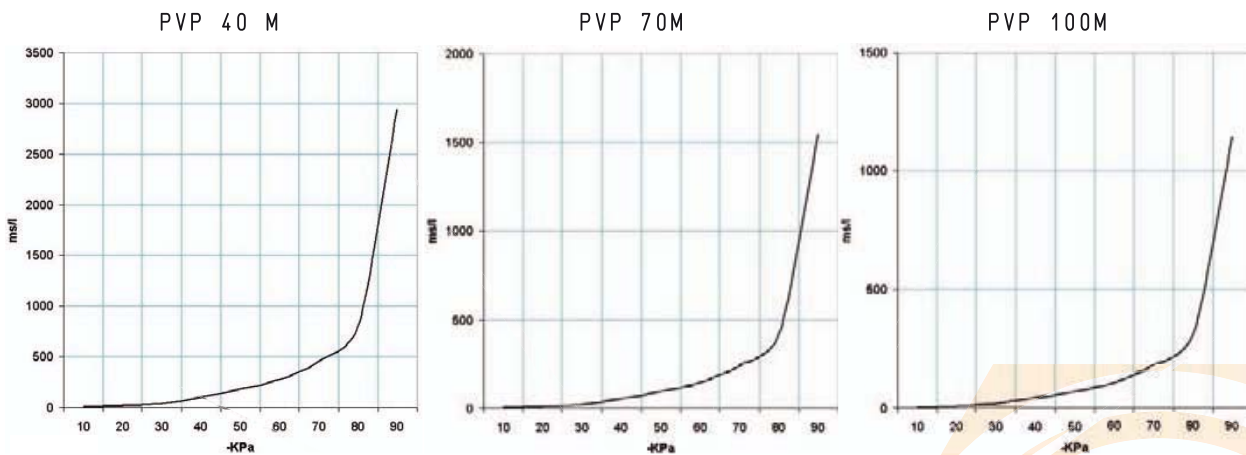

Generator art.	Supply press. bar (g)	Air consumption NI/s	Evacuation time (ms/l = s/m ³) at different vacuum levels (-KPa)										Max. vacuum level -KPa
			10	20	30	40	50	60	70	80	90		
PVP 40 M	6.0	3.2	7.7	19.2	42.3	101.6	182.0	278.4	462.3	799.8	2943	90	
PVP 70 M	6.0	6.6	4.0	10.1	22.2	53.3	95.5	146.1	242.6	419.7	1544	90	
PVP 100 M	6.0	9.8	3.0	7.4	16.4	39.5	70.7	108.2	179.6	310.8	1144	90	

MULTI-STAGE VACUUM GENERATORS PVP 140 M, 170 M and 200 M

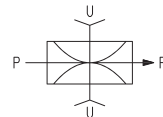
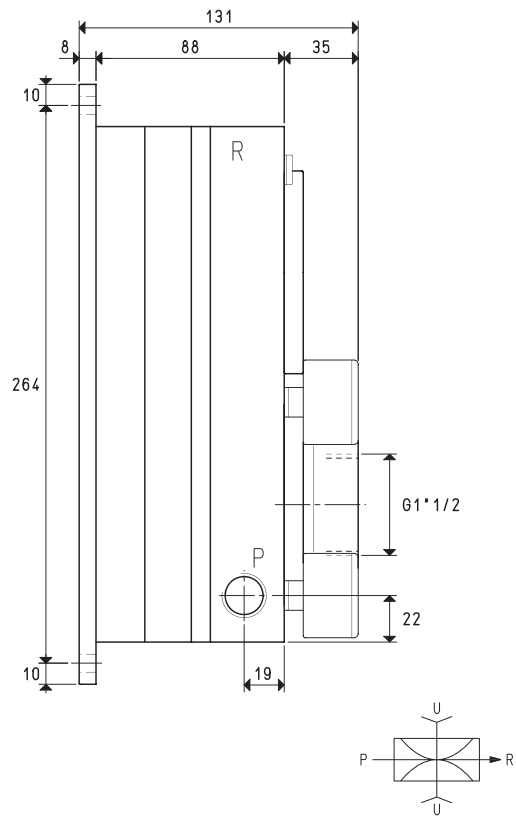
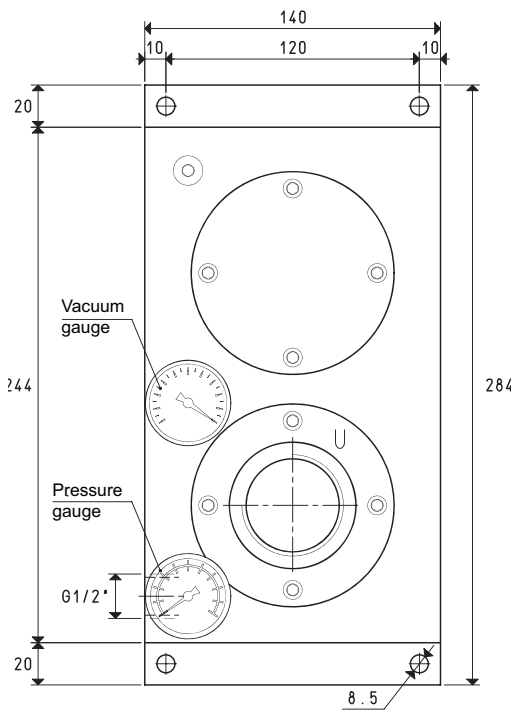

3D drawing available at www.vuototecnica.net

Art.	P=COMPRESSED AIR CONNECTION	R=EXHAUST	U=VACUUM CONNECTION						
			PVP 140 M	PVP 170 M	PVP 170 M	PVP 170 M	PVP 170 M	PVP 200 M	
Max. quantity of sucked air	cum/h	125 140	152	150	168	182	170	188	200
Max. vacuum level	-KPa	65 82	90	65	82	90	65	82	90
Final pressure	mbar abs.	350 180	100	350	180	100	350	180	100
Supply pressure	bar (g)	4 5	6	4	5	6	4	5	6
Air consumption	Nl/s	9.6 11.4	13.0	12.1	14.2	16.3	14.2	16.9	19.4
Working temperature	°C		-20 / +80			-20 / +80			-20 / +80
Noise level	dB(A)		70			71			72
Weight	Kg		5.1			5.1			5.1
Spare parts									
Sealing kit e disc valves	art.		00 KIT PVP 140 M			00 KIT PVP 170 M			00 KIT PVP 200 M
Vacuum gauge	art.		09 03 15			09 03 15			09 03 15
Pressure gauge	art.		09 03 25			09 03 25			09 03 25

Note: All the vacuum data indicated in the table are valid at the normal atmospheric pressure of 1013 mbar and are obtained with a constant supply pressure.

By adding the letter R to the article, the generator will be supplied with a built-in check valve (E.g.: PVP 140 MR).

8.70

Conversion ratio: inch = $\frac{mm}{25.4}$; pounds = $\frac{g}{453.6} = \frac{Kg}{0.4536}$

GAS-NPT thread adapters available at page 1.117



MULTI-STAGE VACUUM GENERATORS PVP 140 M, 170 M and 200 M

Air capacity (NI/s) at different vacuum levels (-Kpa)

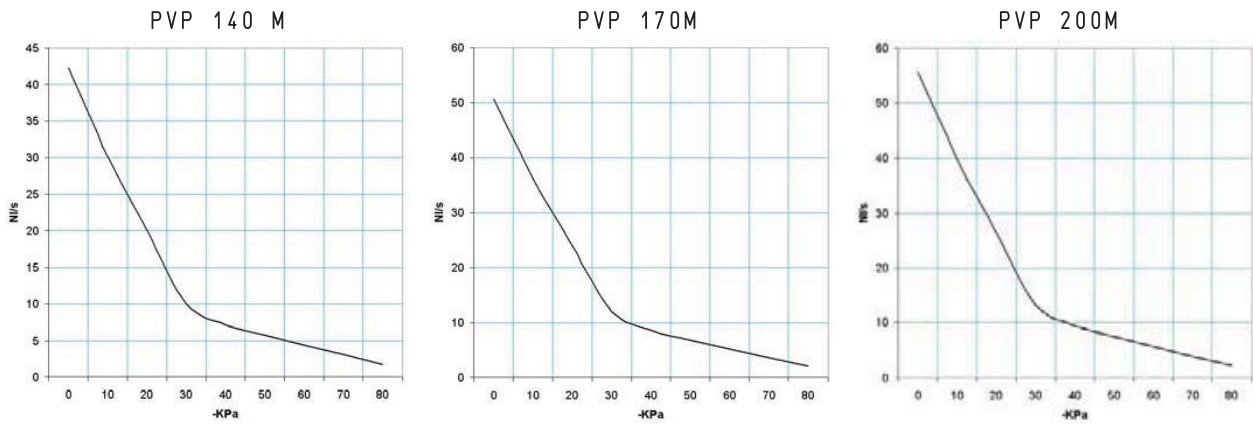

Generator art.	Supply press. bar (g)	Air consumption NI/s	Air capacity (NI/s) at different vacuum levels (-KPa)										Max. vacuum level -KPa
			0	10	20	30	40	50	60	70	80		
PVP 140 M	6.0	13.0	42.22	30.15	20.10	10.05	7.18	5.74	4.31	3.02	1.72	90	
PVP 170 M	6.0	16.3	50.55	36.10	24.07	12.03	8.59	6.87	5.17	3.61	2.06	90	
PVP 200 M	6.0	19.4	55.55	39.67	26.45	13.22	9.44	7.55	5.68	3.97	2.27	90	

Evacuation time (ms/l= s/m^3) at different vacuum levels (-Kpa)

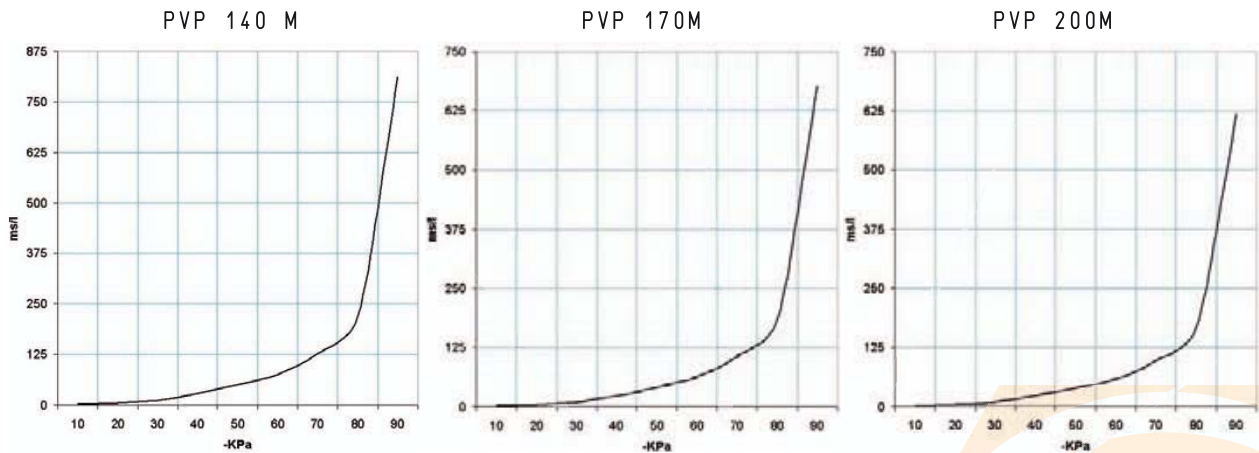

Generator art.	Supply press. bar (g)	Air consumption NI/s	Evacuation time (ms/l = s/m^3) at different vacuum levels (-KPa)										Max. vacuum level -KPa
			10	20	30	40	50	60	70	80	90		
PVP 140 M	6.0	13.0	2.1	5.3	11.7	28.0	50.2	76.9	127.6	220.8	812	90	
PVP 170 M	6.0	16.3	1.7	4.4	9.7	23.4	42.0	64.2	106.6	184.5	678	90	
PVP 200 M	6.0	19.4	1.6	4.0	8.9	21.3	38.2	58.4	97.0	167.8	618	90	



MULTI-STAGE VACUUM GENERATORS PVP 250 M and 300 M

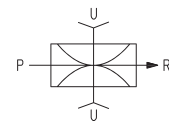
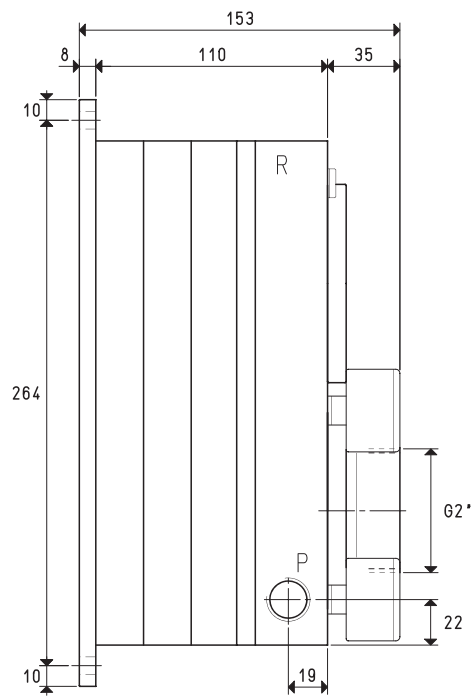
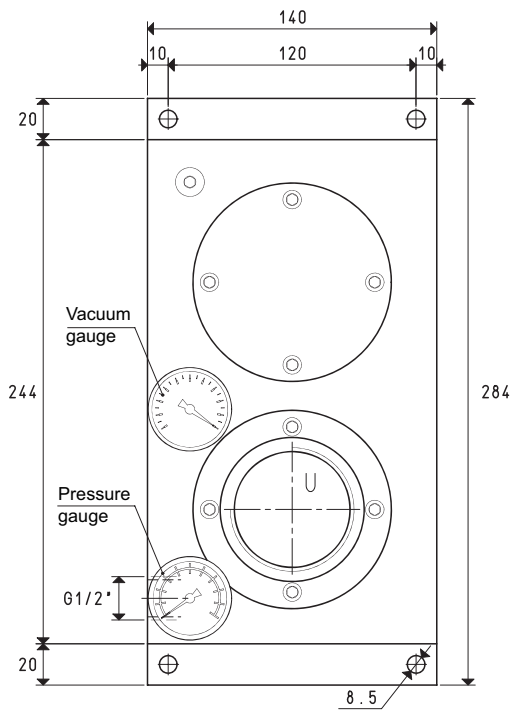

P=COMPRESSED AIR CONNECTION R=EXHAUST U=VACUUM CONNECTION

Art.		PVP 250 M		PVP 300 M	
Max. quantity of sucked air	cum/h	224	252	280	240
Max. vacuum level	-KPa	65	82	90	65
Final pressure	mbar abs.	350	180	100	350
Supply pressure	bar (g)	4	5	6	4
Air consumption	NI/s	17.3	20.7	24.0	20.4
Working temperature	°C			-20 / +80	
Noise level	dB(A)			72	
Weight	Kg			6.0	
Spare parts					
Sealing kit e disc valves	art.			00 KIT PVP 250 M	00 KIT PVP 300 M
Vacuum gauge	art.			09 03 15	09 03 15
Pressure gauge	art.			09 03 25	09 03 25

Note: All the vacuum data indicated in the table are valid at the normal atmospheric pressure of 1013 mbar and are obtained with a constant supply pressure.

By adding the letter R to the article, the generator will be supplied with a built-in check valve (E.g.: PVP 250 MR).

3D drawing available at www.vuototecnica.net

8.72

Conversion ratio: inch = $\frac{mm}{25.4}$; pounds = $\frac{g}{453.6} = \frac{Kg}{0.4536}$

GAS-NPT thread adapters available at page 1.117



8



MULTI-STAGE VACUUM GENERATORS PVP 250 M and 300 M

Air capacity (NI/s) at different vacuum levels (-Kpa)

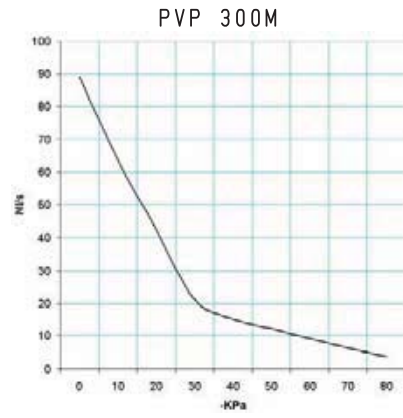
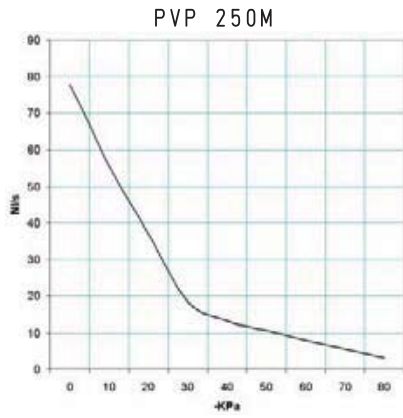

Generator art.	Supply press. bar (g)	Air consumption NI/s	Air capacity (NI/s) at different vacuum levels (-KPa)										Max. vacuum level -KPa
			0	10	20	30	40	50	60	70	80	90	
PVP 250 M	6.0	24.0	77.77	55.55	37.03	18.51	13.22	10.58	7.95	5.56	3.17	90	
PVP 300 M	6.0	29.0	88.88	63.48	42.32	21.16	15.11	12.09	9.09	6.35	3.63	90	

Evacuation time (ms/l= s/m^3) at different vacuum levels (-Kpa)

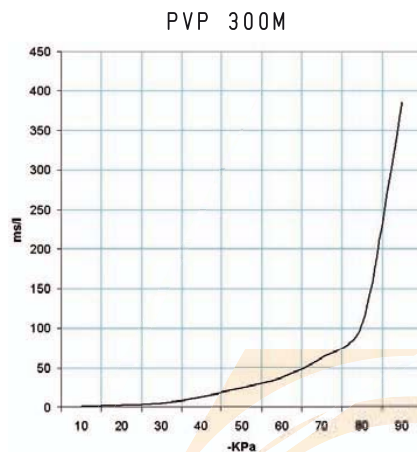
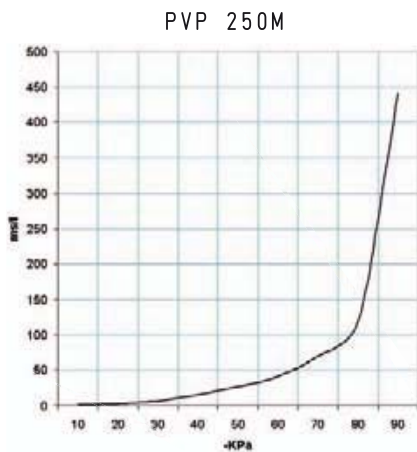

Generator art.	Supply press. bar (g)	Air consumption NI/s	Evacuation time (ms/l = s/m^3) at different vacuum levels (-KPa)										Max. vacuum level -KPa
			10	20	30	40	50	60	70	80	90		
PVP 250 M	6.0	24.0	1.1	2.9	6.4	15.2	27.3	41.8	69.3	119.9	442	90	
PVP 300 M	6.0	29.0	1.0	2.5	5.5	13.3	23.8	36.5	60.6	104.9	386	90	