

MULTI-STAGE VACUUM GENERATORS - GENERAL INFORMATION

Our multi-stage vacuum generators produce a maximum vacuum of 90%, equal to a final vacuum level of 100 mbar abs., with different suction capacities. They operate by use of compressed air from 1 to 6 bar (g).

Working principle

Each ejector is based on the Venturi principle: the supply fluid (compressed air) is led high speed by a convergent pipe into the fluid to be extracted (volume of the air to be sucked). This mixture is then led into two or three divergent pipes, where its kinetic energy is transformed into pressure energy for it to enter in the environment at a higher pressure (atmospheric pressure at the exhaust).

Technical features

The main asset of multi-stage vacuum generators is its ability to exploit the kinetic energy of the supply compressed air via several specially dimensioned in-line ejectors, before releasing it in the atmosphere. This system allows, given the same capacity, a reduced compressed air consumption compared to the single-stage vacuum generators.

The suction capacity is indirectly proportional to the differential between the pressure of the fluid to be sucked and the external (atmospheric) pressure.

The reduced size and weight make multi-stage vacuum generators compact in relation to their great suction capacity.

The absence of moving parts make them particularly silent and allow them to be used continuously, without developing heat.

Being supplied exclusively by compressed air, these vacuum generators are explosion-proof and can be used in work environments with temperatures ranging from -20 to +80 °C.

They are fully made with stainless materials.

Thanks to all these features, a good filtration of the supply and sucked compressed air is sufficient to make these generators are fully maintenance-free.

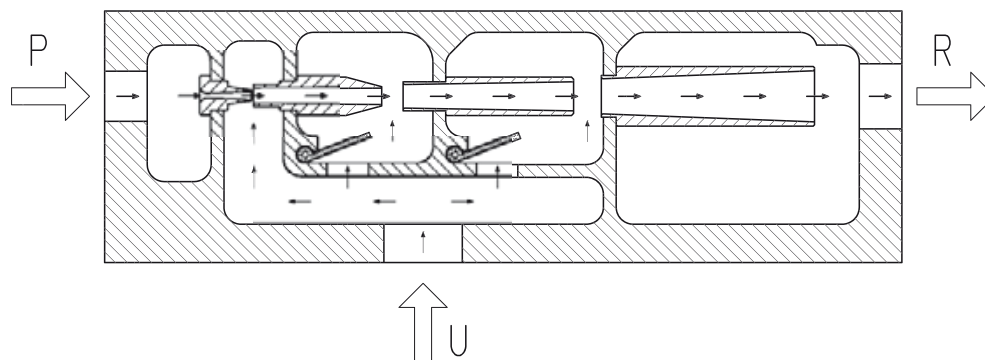

P = Compressed air connection
R = Exhaust
U = Vacuum connection

