

MODULAR MULTI-STAGE VACUUM GENERATORS PVP 150 ÷ 600 MD

The special shape of these vacuum generators has allowed obtaining great suction capacities in very limited overall dimensions. The ejectors share the same features as the previous ones, but instead of being fixed directly onto the generator body, they are assembled onto modular frames. The superimposition of one or more frames determines the generator capacity. They are supplied by filtered compressed air with an optimal pressure of 6 bar (g), and they can create a maximum vacuum of 90%, with a suction capacity ranging from 200 to 750 cum/h, measured at the normal atmospheric pressure of 1013 mbar. They are fully made with anodised aluminium with disc valves and special compound seals. They are perfectly soundproofed which results in an extremely silent operation.

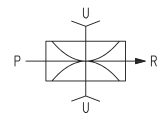

MODULAR MULTI-STAGE VACUUM GENERATORS PVP 150 MD and 300 MD

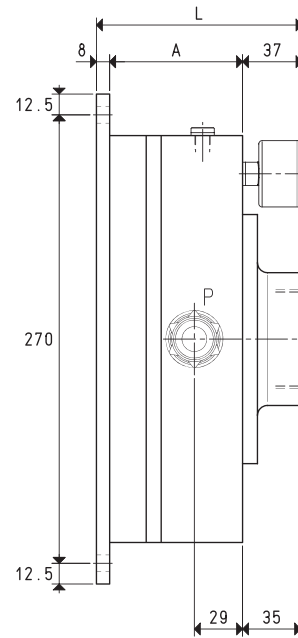
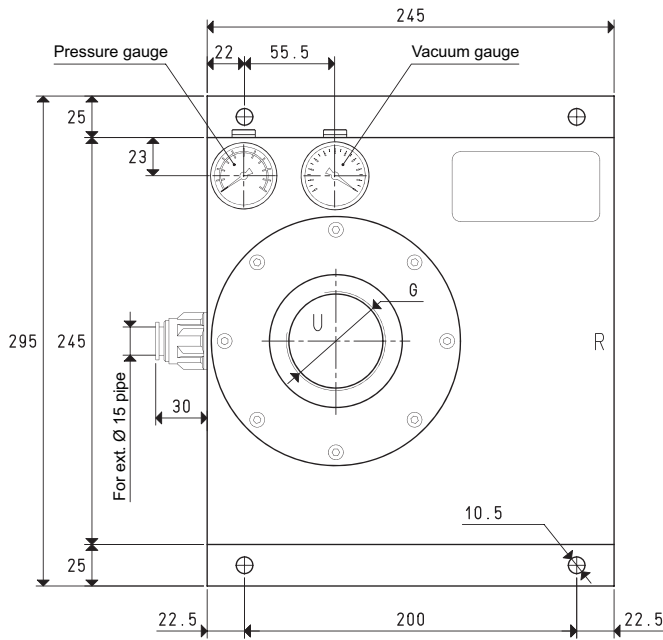

P=COMPRESSED AIR CONNECTION R=EXHAUST U=VACUUM CONNECTION

Art.				PVP 150 MD		PVP 300 MD	
Max. quantity of sucked air	cum/h	160	180	200	320	360	400
Max. vacuum level	-KPa	65	82	90	65	82	90
Final pressure	mbar abs.	350	180	100	350	180	100
Supply pressure	bar (g)	4	5	6	4	5	6
Air consumption	NI/s	12.1	14.2	16.0	23.2	27.8	32.0
Working temperature	°C			-20 / +80		-20 / +80	
Noise level	dB(A)			72		74	
Weight	Kg			7.8		8.8	
A				80		100	
G	Ø			G1" 1/2		G2"	
L				125		145	
Spare parts							
Sealing kit e disc valves	art.			00 KIT PVP 150 MD		00 KIT PVP 300 MD	
Vacuum gauge	art.			09 03 15		09 03 15	
Pressure gauge	art.			09 03 25		09 03 25	

Note: All the vacuum data indicated in the table are valid at the normal atmospheric pressure of 1013 mbar and are obtained with a constant supply pressure.

By adding the letter R to the article, the generator will be supplied with a built-in check valve (E.g.: PVP 300 MDR).

3D drawing available at www.vuototecnica.net

8.82

Conversion ratio: inch = $\frac{\text{mm}}{25.4}$; pounds = $\frac{\text{g}}{453.6} = \frac{\text{Kg}}{0.4536}$

GAS-NPT thread adapters available at page 1.117



8



MODULAR MULTI-STAGE VACUUM GENERATORS PVP 150 MD and 300 MD

Air capacity (NI/s) at different vacuum levels (-Kpa)

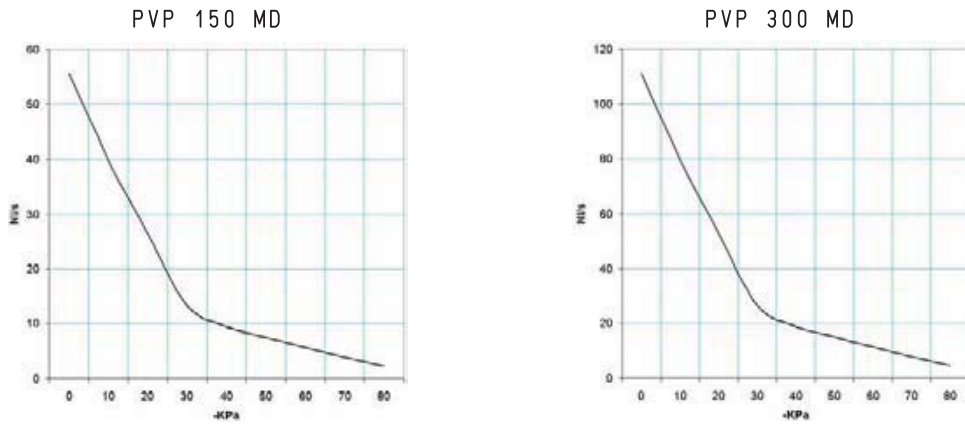

Generator art.	Supply press. bar (g)	Air consumption NI/s	Air capacity (NI/s) at different vacuum levels (-KPa)										Max. vacuum level -KPa
			0	10	20	30	40	50	60	70	80	90	
PVP 150 MD	6.0	16	55.55	39.68	26.45	13.22	9.44	7.55	5.68	3.97	2.27	90	
PVP 300 MD	6.0	32	111.11	79.36	52.91	26.45	19.89	15.11	11.36	7.94	4.54	90	

Evacuation time (ms/l=s/m³) at different vacuum levels (-Kpa)

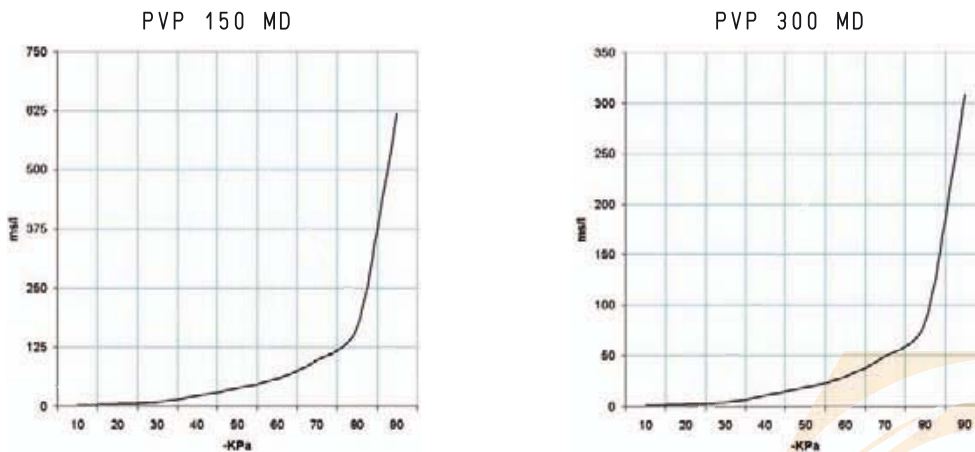

Generator art.	Supply press. bar (g)	Air consumption NI/s	Evacuation time (ms/l = s/m ³) at different vacuum levels (-KPa)									Max. vacuum level -KPa
			10	20	30	40	50	60	70	80	90	
PVP 150 MD	6.0	16	1.6	4.0	8.9	21.3	38.2	58.4	97.0	167.8	618	90
PVP 300 MD	6.0	32	0.8	2.0	4.4	10.6	19.1	29.2	48.5	83.9	386	90

MODULAR MULTI-STAGE VACUUM GENERATORS PVP 450 MD and 600 MD

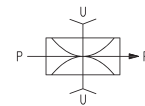
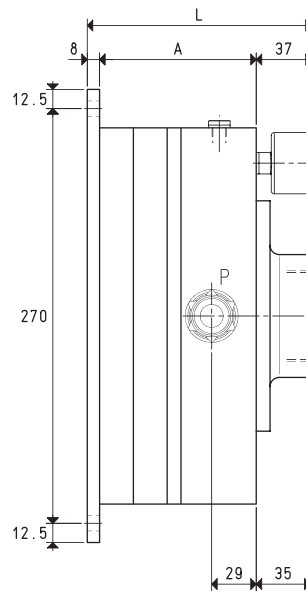
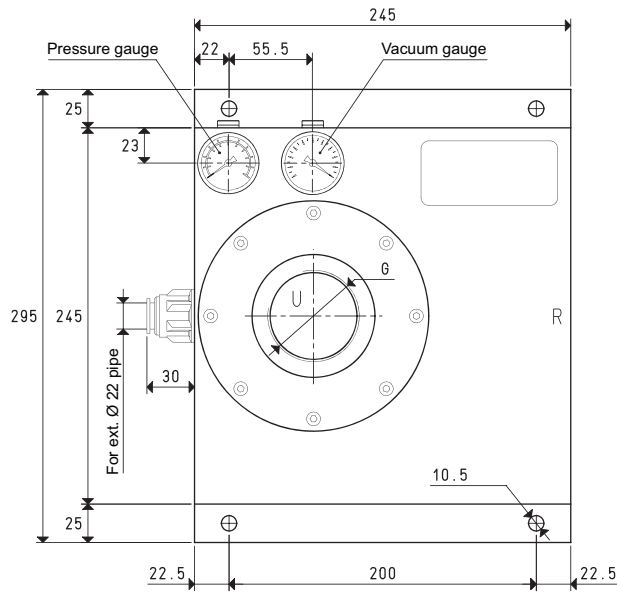

P=COMPRESSED AIR CONNECTION R=EXHAUST U=VACUUM CONNECTION

Art.				PVP 450 MD			PVP 600 MD	
Max. quantity of sucked air	cum/h	490	530	580	640	700	750	
Max. vacuum level	-KPa	65	82	90	65	82	90	
Final pressure	mbar abs.	350	180	100	350	180	100	
Supply pressure	bar (g)	4	5	6	4	5	6	
Air consumption	NI/s	34.4	39.4	47.8	43.2	53.5	63.2	
Working temperature	°C			-20 / +80			-20 / +80	
Noise level	dB(A)			74			78	
Weight	Kg			9.9			11.1	
A				122			142	
G	Ø			G2" 1/2			G3"	
L				167			187	
Spare parts								
Sealing kit e disc valves	art.			00 KIT PVP 450 MD			00 KIT PVP 600 MD	
Vacuum gauge	art.			09 03 15			09 03 15	
Pressure gauge	art.			09 03 25			09 03 25	

Note: All the vacuum data indicated in the table are valid at the normal atmospheric pressure of 1013 mbar and are obtained with a constant supply pressure.

By adding the letter R to the article, the generator will be supplied with a built-in check valve (E.g.: PVP 450 MDR).

3D drawing available at www.vuototecnica.net

8.84

Conversion ratio: inch = $\frac{mm}{25.4}$; pounds = $\frac{g}{453.6} = \frac{Kg}{0.4536}$

GAS-NPT thread adapters available at page 1.117



8



MODULAR MULTI-STAGE VACUUM GENERATORS PVP 450 MD and 600 MD

Air capacity (NI/s) at different vacuum levels (-Kpa)

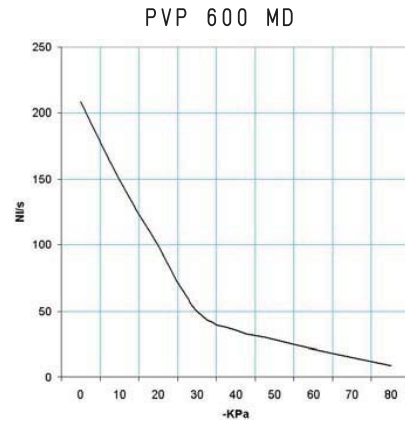
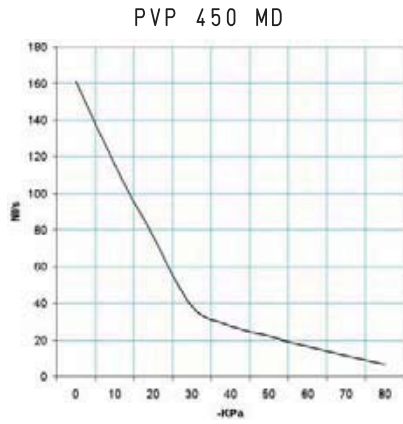

Generator art.	Supply press. bar (g)	Air consumption NI/s	Air capacity (NI/s) at different vacuum levels (-KPa)										Max. vacuum level -KPa
			0	10	20	30	40	50	60	70	80		
PVP 450 MD	6.0	47.8	161.11	115.07	76.71	38.35	27.39	21.91	16.48	11.52	6.58	90	
PVP 600 MD	6.0	63.2	208.33	148.80	99.20	49.60	35.43	28.34	21.31	14.90	8.51	90	

Evacuation time (ms/l = s/m³) at different vacuum levels (-Kpa)

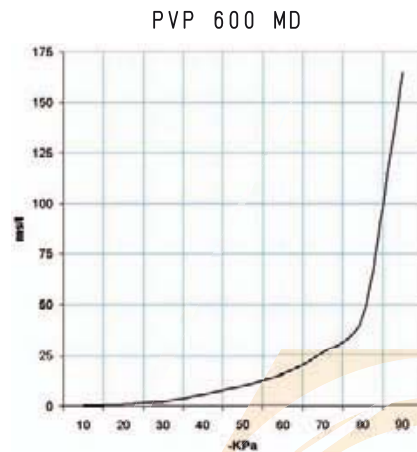
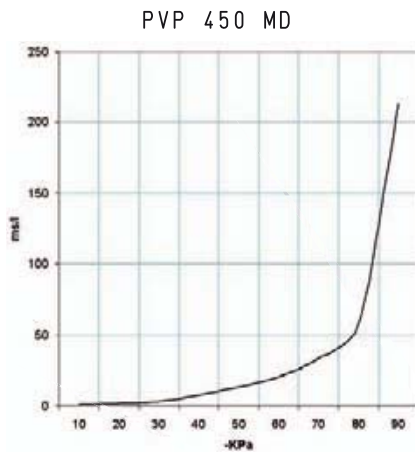

Generator art.	Supply press. bar (g)	Air consumption NI/s	Evacuation time (ms/l = s/m ³) at different vacuum levels (-KPa)										Max. vacuum level -KPa
			10	20	30	40	50	60	70	80	90		
PVP 450 MD	6.0	47.8	0.5	1.4	3.0	7.4	13.2	20.1	33.5	57.9	213	90	
PVP 600 MD	6.0	63.2	0.4	1.0	2.4	5.7	10.2	15.6	25.9	44.8	165	90	

