

FLOW GENERATOR VACUUM JET



Working principle

The compressed air supply blown into a ring chamber concentric to the device, flows at a very high speed towards the centre of the main pipe, thus forming a cyclonic effect. The latter creates a vacuum inside the device and leads a great volume of air towards its outlet. Therefore, a variation of the air supply pressure will modify the vacuum level and the amount of sucked air.

Features

The special shape of these adjustable vacuum generators, as well as their straight-flow working principle allow sucking and transferring products of various nature with no interference. In fact, Vacuum Jet flow generators are suited for transferring powders, granulated products, sawdust, metal chips, dry or liquid food products, etc. They are also recommended for controlling vacuum cups in presence of large amounts of dust or liquids, as well as for sucking fumes, cooling mists, water and oil condensation, etc. The absence of moving parts allows for a continuous use without developing heat.

Available in anodised aluminium and stainless steel.

Thanks to all these features, a good filtration of the compressed air supply will be sufficient to make these devices fully maintenance-free.

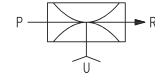
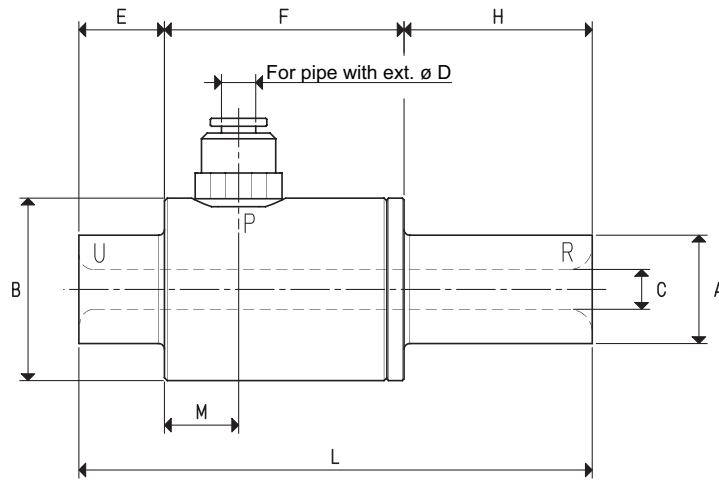

	P=COMPRESSED AIR CONNECTION	R=EXHAUST	U=VACUUM CONNECTION	
Art.				CX 7 CX 10
Max. quantity of sucked air at 6 bar (g)		cum/h		12.0 28.0
Max. quantity of blown air at 6 bar (g)		cum/h		17.6 51.4
Max. vacuum level		-kPa		15 22
Final pressure		mbar abs.		850 780
Max pressione di alimentazione		bar (g)		6 6
Air consumption at 6 bar (g)		NI/s		1.5 6.5
Working temperature		°C		-20 / +80 -20 / +80
Noise level		dB(A)		75 84
Weight		g		110 104
A		∅		19 19
B		∅		32 32
C		∅		7 10
D		∅		6 6
E				15 15
F				42 42
H				33 33
L				90 90
M				13 13

Note: All the vacuum data indicated in the table are valid at the normal atmospheric pressure of 1013 mbar and are obtained with a constant supply pressure.

By adding the letter I to the article, the generator will be supplied in the stainless steel version (E.g.: CX 10 I).

Conversion ratio: inch = $\frac{mm}{25.4}$; pounds = $\frac{g}{453.6}$ = $\frac{Kg}{0.4536}$

GAS-NPT thread adapters available at page 1.117

8.91

3D drawing available at www.vuototecnica.net



FLOW GENERATOR VACUUM JET, CX 7 and CX 10

Quantity of sucked air (cum/h) at different supply pressures (bar)

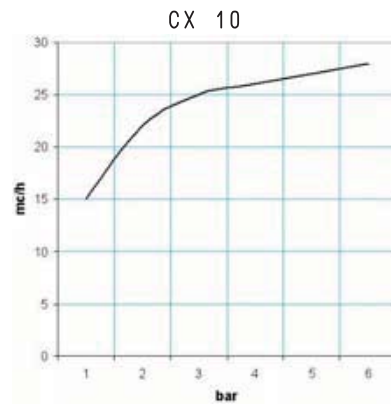
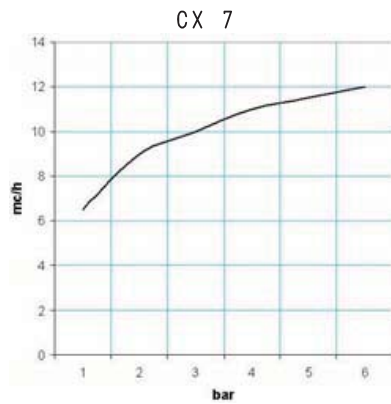

Quantity of blown air (cum/h) at different supply pressures (bar)

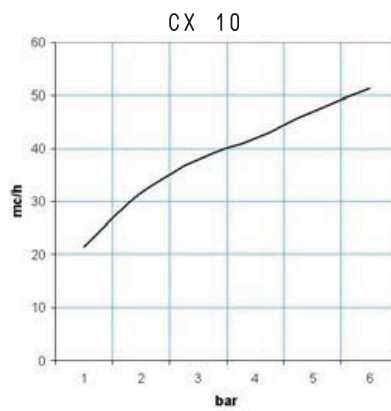
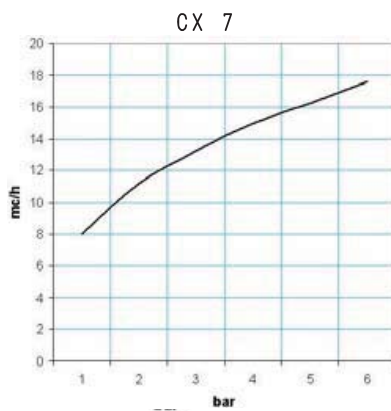

Vacuum level (-Kpa) at different supply pressures (bar)

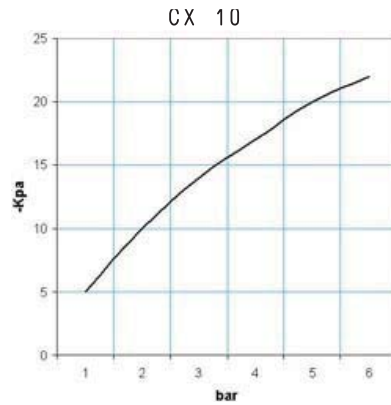
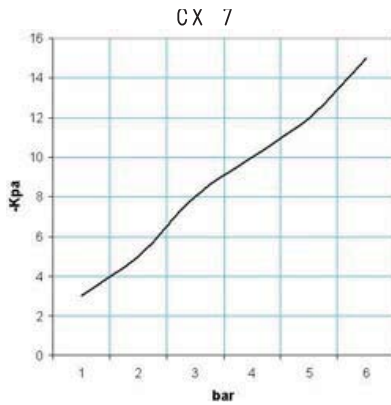

Air consumption (NI/s) at different supply pressures (bar)

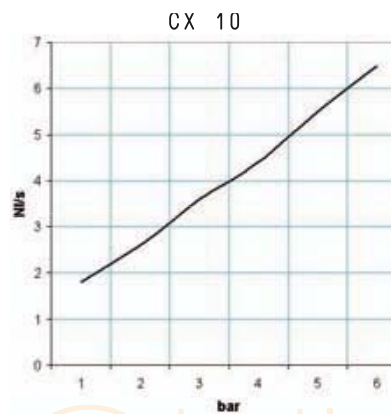
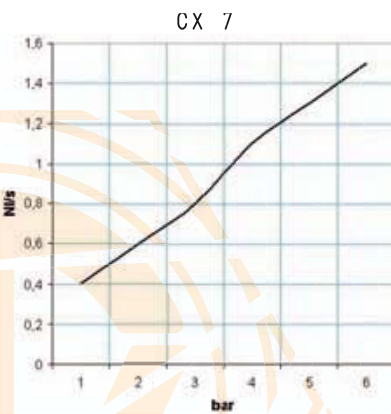

3D drawing available at www.vuototecnica.net

FLOW GENERATOR VACUUM JET, CX 13 and CX 19

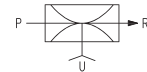
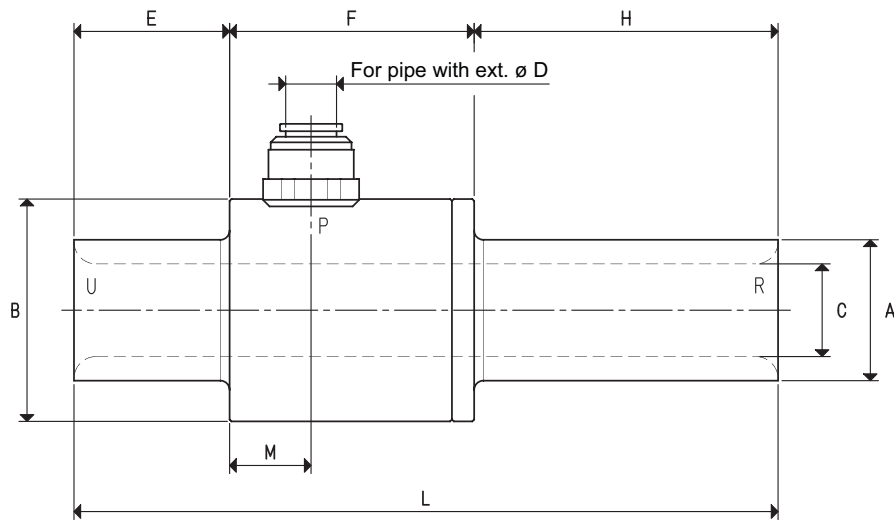

	P=COMPRESSED AIR CONNECTION	R=EXHAUST	U=VACUUM CONNECTION	
Art.				CX 13 CX 19
Max. quantity of sucked air at 6 bar (g)		cum/h		50.0 92.0
Max. quantity of blown air at 6 bar (g)		cum/h		73.7 134.0
Max. vacuum level		-kPa		18 16
Final pressure		mbar abs.		820 840
Max pressione di alimentazione		bar (g)		6 6
Air consumption at 6 bar (g)		NI/s		6.6 11.6
Working temperature		°C		-20 / +80 -20 / +80
Noise level		dB(A)		88 92
Weight		g		280 500
A		∅		25 32
B		∅		45 54
C		∅		13 19
D		∅		8 10
E				30 43
F				55 65
H				55 82
L				140 190
M				18 22

Note: All the vacuum data indicated in the table are valid at the normal atmospheric pressure of 1013 mbar and are obtained with a constant supply pressure.

By adding the letter I to the article, the generator will be supplied in the stainless steel version (E.g.: CX 13 I).

Conversion ratio: inch = $\frac{mm}{25.4}$; pounds = $\frac{g}{453.6}$ = $\frac{Kg}{0.4536}$

GAS-NPT thread adapters available at page 1.117

8.93

3D drawing available at www.vuototecnica.net

FLOW GENERATOR VACUUM JET, CX 13 and CX 19

Quantity of sucked air (cum/h) at different supply pressures (bar)

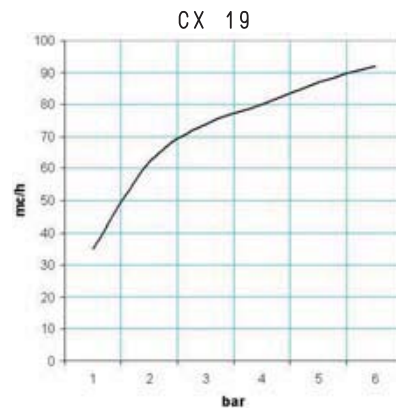
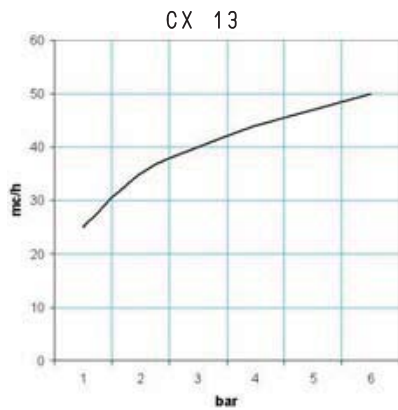

Quantity of blown air (cum/h) at different supply pressures (bar)

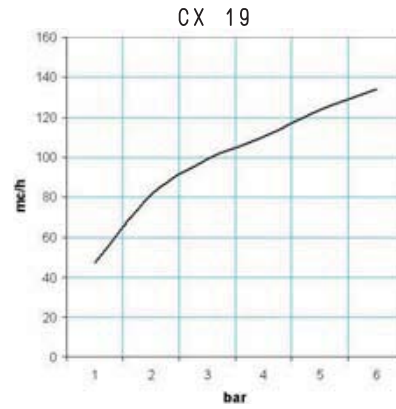
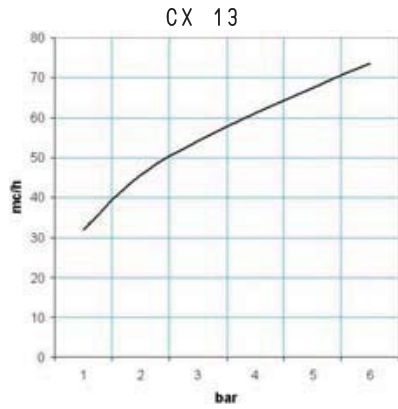

Vacuum level (-Kpa) at different supply pressures (bar)

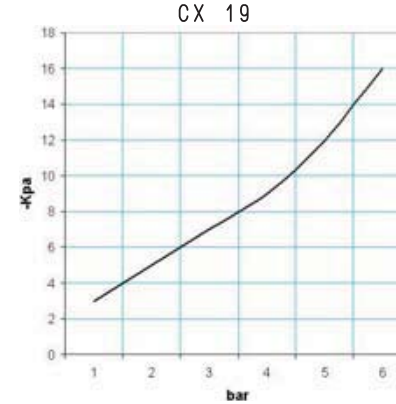
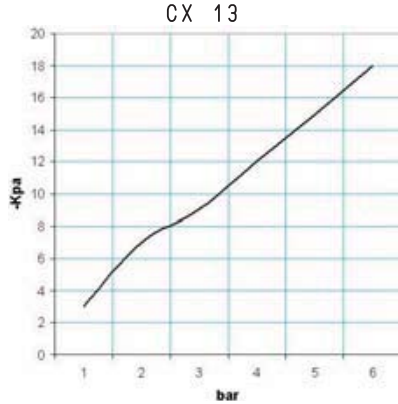

Air consumption (NI/s) at different supply pressures (bar)

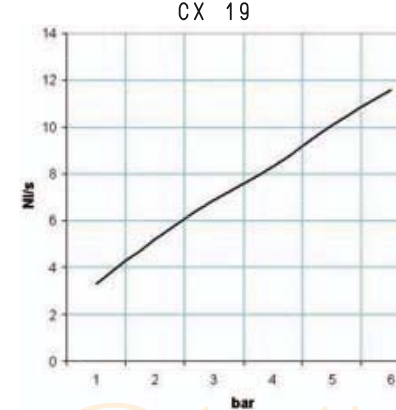
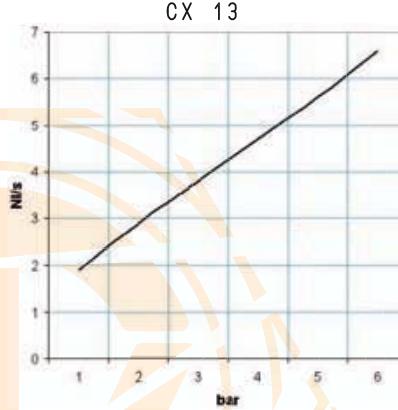

3D drawing available at www.vuototecnica.net



FLOW GENERATOR VACUUM JET, CX 25, CX 38 and CX 50

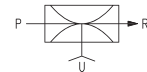
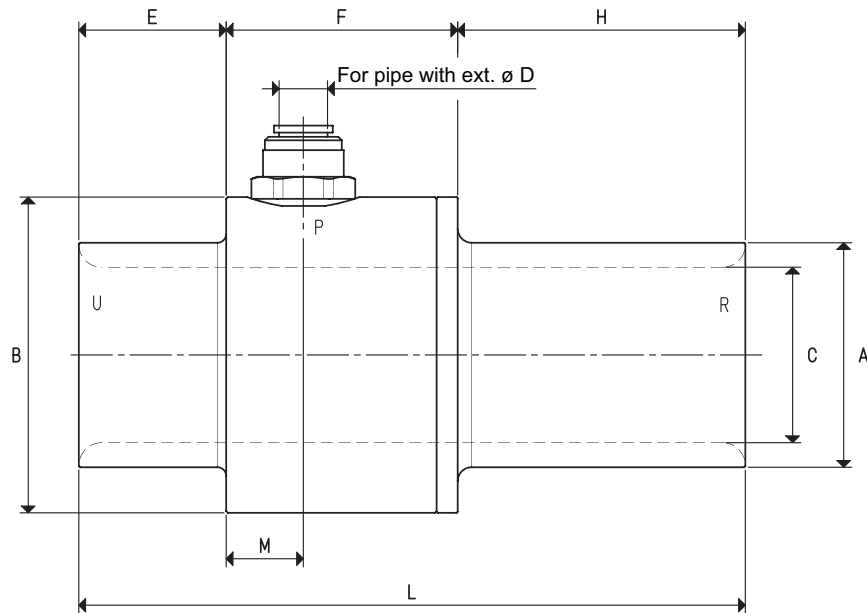

	P=COMPRESSED AIR CONNECTION	R=EXHAUST	U=VACUUM CONNECTION		
Art.			CX 25	CX 38	CX 50
Max. quantity of sucked air at 6 bar (g)		cum/h	150	310	405
Max. quantity of blown air at 6 bar (g)		cum/h	210	400	525
Max. vacuum level		-KPa	13	10	8
Final pressure		mbar abs.	870	900	920
Max. supply pressure		bar (g)	6.0	6.0	6.0
Air consumption at 6 bar (g)		NI/s	16.6	25.0	33.3
Working temperature		°C	-20 / +80	-20 / +80	-20 / +80
Noise level		dB(A)	100	103	103
Weight		g	560	800	1090
A		∅	38	51	54
B		∅	60	75	90
C		∅	25	38	50
D		∅	10	12	16
E			42	42	42
F			66	66	66
H			82	82	82
L			190	190	190
M			22	22	22

Note: All the vacuum data indicated in the table are valid at the normal atmospheric pressure of 1013 mbar and are obtained with a constant supply pressure.

By adding the letter I to the article, the generator will be supplied in the stainless steel version (E.g.: CX 38 I).

Conversion ratio: inch = $\frac{mm}{25.4}$; pounds = $\frac{g}{453.6} = \frac{Kg}{0.4536}$

GAS-NPT thread adapters available at page 1.117

8.95

3D drawing available at www.vuototecnica.net

FLOW GENERATOR VACUUM JET, CX 25, CX 38 and CX 50

Quantity of sucked air (cum/h) at different supply pressures (bar)

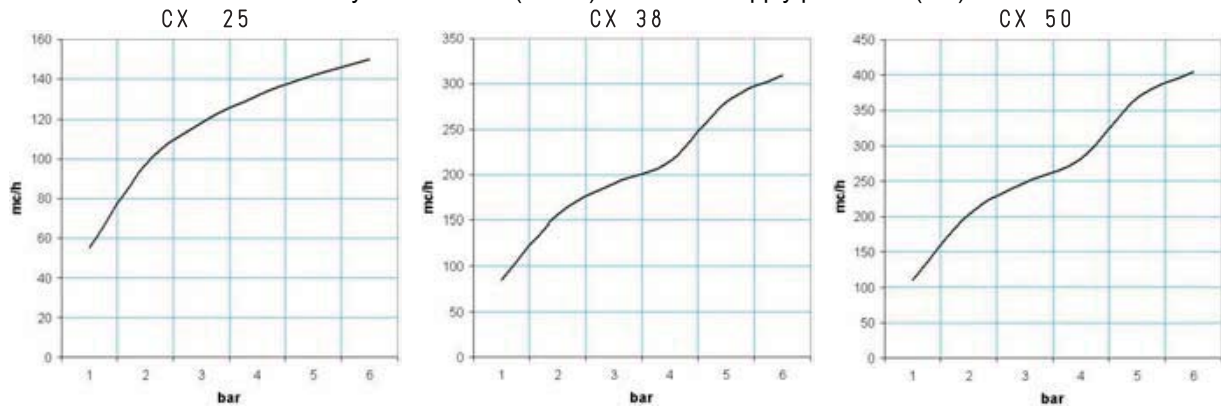

Quantity of blown air (cum/h) at different supply pressures (bar)

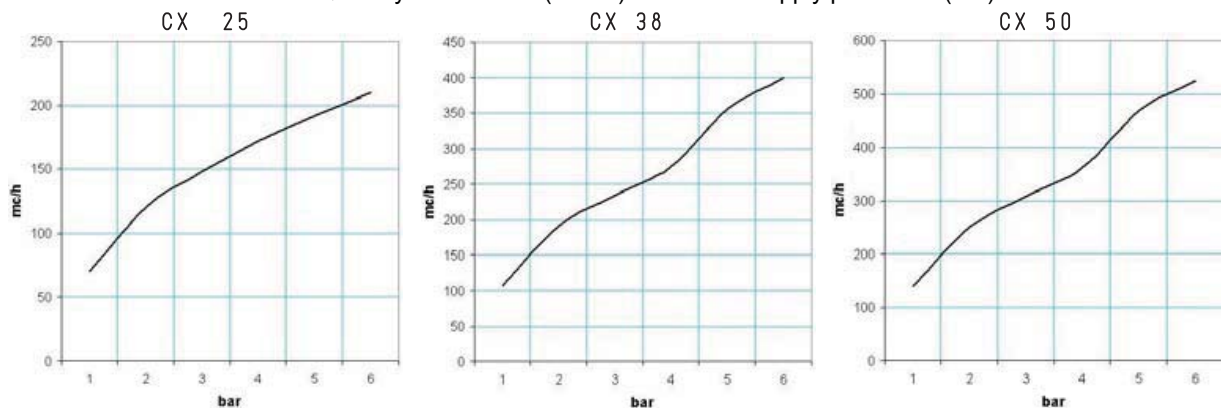

Vacuum level (-Kpa) at different supply pressures (bar)

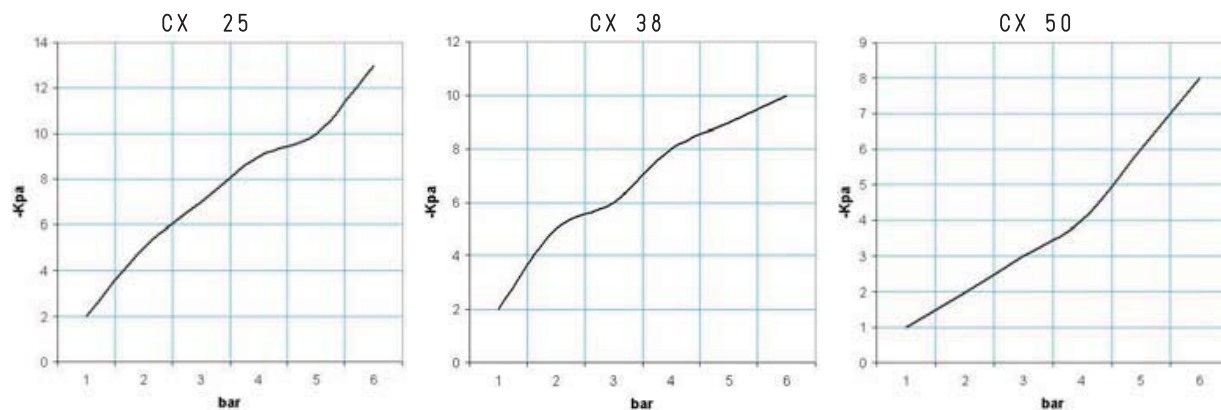

Air consumption (Nl/s) at different supply pressures (bar)

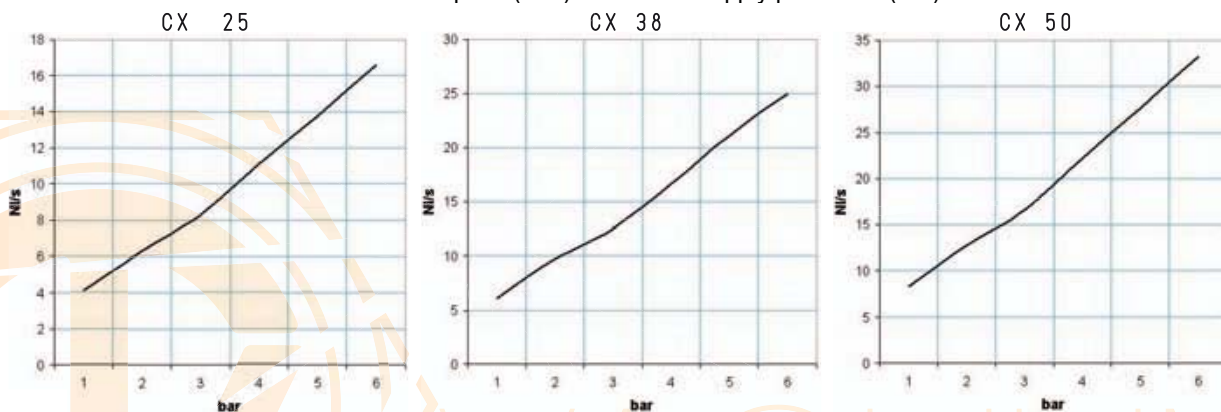

3D drawing available at www.vuototecnica.net