

DIRECT DRIVE 3-WAY VACUUM SOLENOID VALVES

These direct drive 3-way, 2-position vacuum solenoid valves feature conical shutters servo-controlled by the vacuum.

As a standard they are normally closed, but they can be supplied normally open upon request. They are composed of an anodised aluminium body where the connections are located, two silicon shutters assembled onto a stainless steel stem and a membrane in special reinforced compound. An actuator activated by an electric coil manages the vacuum at the servo-control. The operating principle of these solenoid valves is based on the pressure differential between the vacuum pump or generator and the pressure of the sucked air.

By addressing this "differential pressure" to the servo-control via the actuator, the shutters can be controlled without compressed air or springs.

Due to their operating principle, they are not recommended on plants with low vacuum levels (below 850 mbar abs., equal to 15 % of vacuum).

The lack of springs, frictions and internal dynamic stresses favours a high response speed and guarantees long lasting operation.

The standard electric coil is fully plasticised with synthetic resin, tight execution, insulation class F (up to 155 °C) compliant with VDE standards, with 6.3 mm 3-terminal electrical connections in compliance with EN 175301-803 (ex DIN 43650). Protection degree IP 54; IP 65 for inserted connector.

Allowed tolerance on the voltage nominal value: ±10%.

Max. absorption: 16.5 V.A. with AC and 16 W with DC.

The electric coil can be rotated by 360°. The connector can be rotated by 180° on the coil and can be supplied, upon request, with Led lights, anti-interference circuit and/or with protection devices against overvoltage and polarity reversal.

The solenoid valves in this series, along with the uses described for the 07 .. 11 series can be used on plants with no compressed air.

They can be provided, upon request, with SM device for manually opening or closing the solenoid valve already installed.

The solenoid valve must be always chosen according to the capacity and, therefore, to the vacuum pump or generator suction connection.

Technical features

Working pressure: from 0.5 to 850 mbar abs.

Temperature of the sucked fluid: from -5 to +60 °C

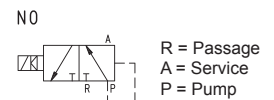
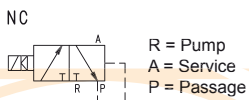
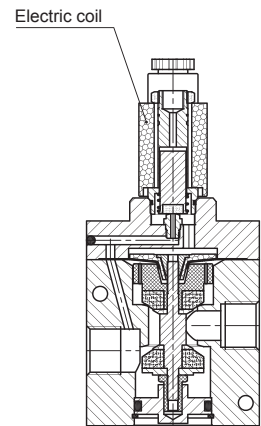
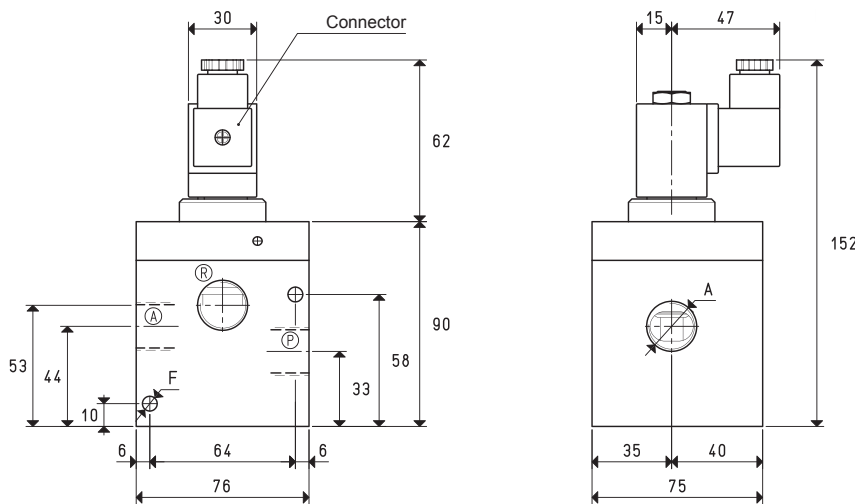

Art.	A	Max. capacity cum/h	Vacuum level mbar abs.		Reaction time msec		Ø orifice	Passage section mm ²	F	Weight Kg
			min	max	exc.	deexc.				
07 03 40 NC	G1/2"	20	850	0.5	30	15	15	176	6.5	1.53
07 03 40 NO					20	18				
07 04 40 NC	G3/4"	40	850	0.5	30	15	20	314	6.5	1.50
07 04 40 NO					20	18				

Note: The coil and the connectors are not integral part of the solenoid valves, therefore, they must be ordered separately (See solenoid valve accessories).

3D drawings available at www.vuototecnica.net

DIRECT DRIVE 3-WAY VACUUM SOLENOID VALVES

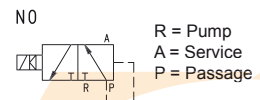
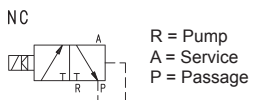
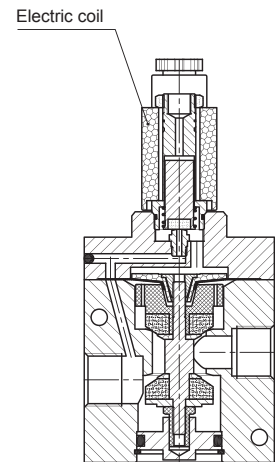
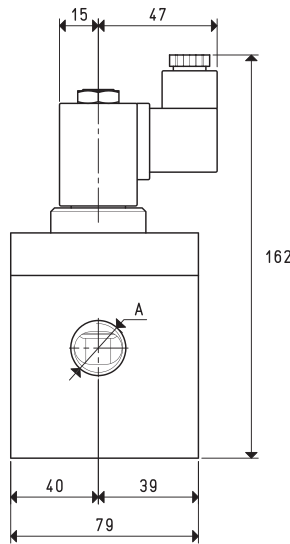
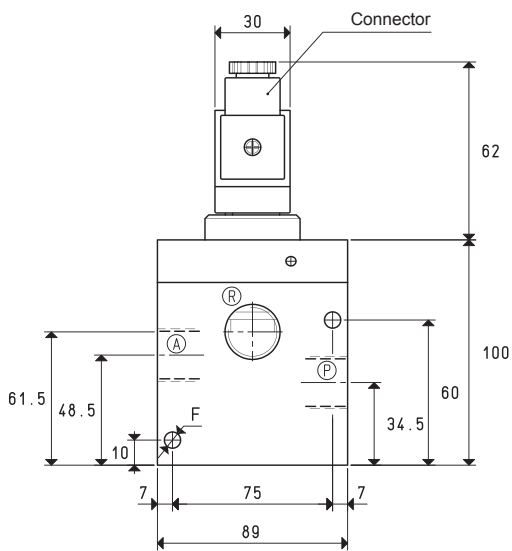

Art.	A	Max. capacity cum/h	Vacuum level mbar abs.		Reaction time msec		Ø orifice	Passage section mm ²	F Ø	Weight Kg
			min	max	exc.	deexc.				
07 05 40 NC	G1"	90	850	0.5	38	18	25	490	6.5	1.91
07 05 40 NO					25	20				

Note: The coil and the connectors are not integral part of the solenoid valves, therefore, they must be ordered separately (See solenoid valve accessories).

DIRECT DRIVE 3-WAY VACUUM SOLENOID VALVES

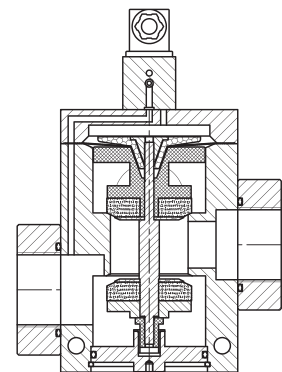
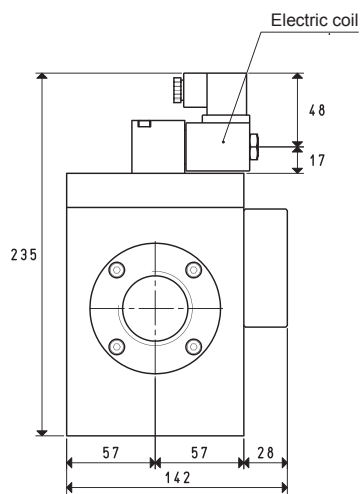
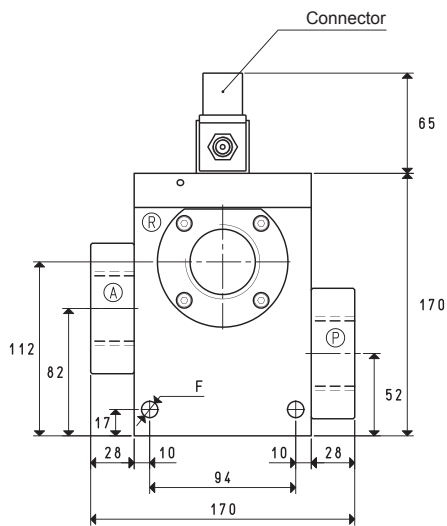

3D drawings available at www.vuototecnica.net

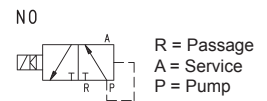
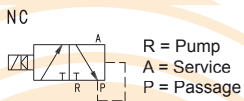

Art.	A	Max. capacity cum/h	Vacuum level mbar abs.		Reaction time msec		Passage section mm ²	Ø orifice	F Ø	Weight Kg
			min	max	exc.	deexc.				
07 06 40 NC	G1" 1/2	180	850	0.5	75	50	1256	40	10.5	5.90
07 06 40 NO					70	60				

Note: The coil and the connectors are not integral part of the solenoid valves, therefore, they must be ordered separately (See solenoid valve accessories).