

SINGLE-STAGE VACUUM GENERATORS WITH EJECTOR 15 02 10 and 15 04 10

The operation of these single-stage vacuum generators is based on the Venturi principle. Supplying the generator with compressed air in P, vacuum will be generated at connection U, while both the supply and the sucked air will be released through R. At the same time, the chamber contained in the generator is also supplied and, as soon as the supply in P is interrupted, it discharges the compressed air that had been collected in it through connection U, thus rapidly restoring the atmospheric pressure at the service.

If, for example, a vacuum cup is connected to the service U, thanks to this system it will disconnect much rapidly than with the vacuum generators described previously. They are fully made with anodised aluminium.

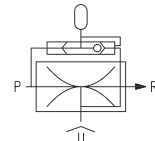
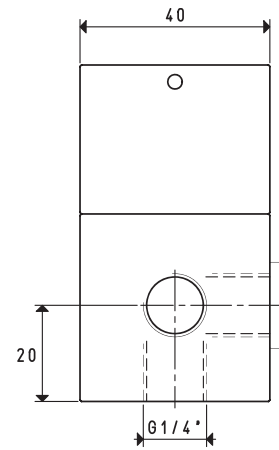
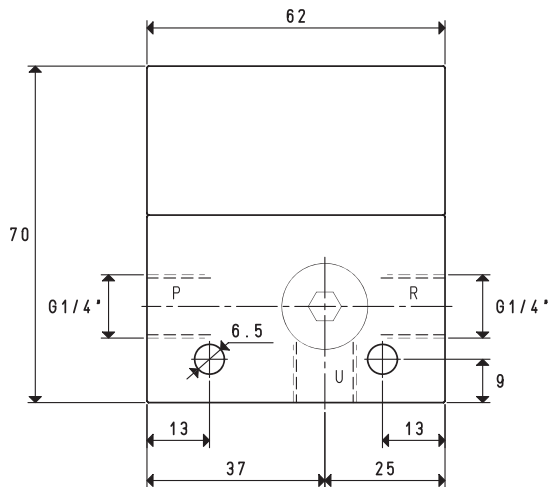

3D drawings available at www.vuototecnica.net

	P=COMPRESSED AIR CONNECTION	R=EXHAUST	U=VACUUM CONNECTION	
Art.				15 02 10
Quantity of sucked air			cum/h	2.7 2.8 2.8
Max. vacuum level			-KPa	55 70 83
Final pressure			mbar abs.	450 300 170
Supply pressure			bar (g)	4 5 6
Air consumption			NI/s	0.7 0.8 0.9
Working temperature			°C	-20 / +80
Noise level			dB(A)	63
Weight			g	319
Spare parts				
Sealing kit			art.	00 15 500

Note: All the vacuum data indicated in the table are valid at the normal atmospheric pressure of 1013 mbar and are obtained with a constant supply pressure.

8.08

Conversion ratio: inch = $\frac{\text{mm}}{25.4}$; pounds = $\frac{\text{g}}{453.6} = \frac{\text{Kg}}{0.4536}$

GAS-NPT thread adapters available at page 1.117



8



SINGLE-STAGE VACUUM GENERATORS WITH EJECTOR 15 02 10

Air capacity (NI/s) at different vacuum levels (-Kpa)

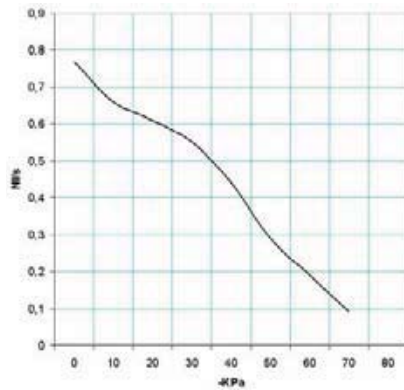

Generator art.	Supply press. bar (g)	Air consumption NI/s	Air capacity (NI/s) at different vacuum levels (-KPa)								Max. vacuum level -KPa	
			0	10	20	30	40	50	60	70		80
15 02 10	6.0	0.9	0.77	0.66	0.61	0.55	0.44	0.29	0.19	0.09	--	83

Evacuation time (ms/l= s/m^3) at different vacuum levels (-Kpa)

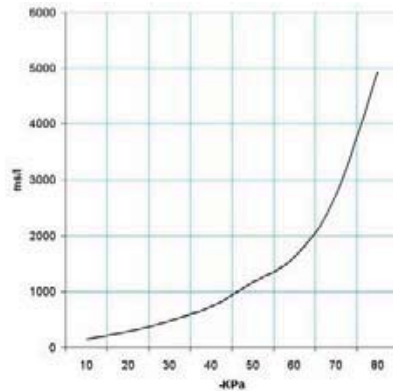

Generator art.	Supply press. bar (g)	Air consumption NI/s	Evacuation time (ms/l = s/m^3) at different vacuum levels (-KPa)							Max. vacuum level -KPa	
			10	20	30	40	50	60	70		80
15 02 10	6.0	0.9	139	278	472	727	1171	1628	2720	4928	83

Accessories upon req
Silencer art. SSX 1/4"

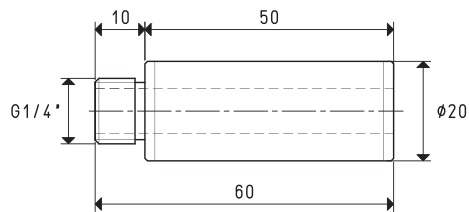

3D drawings available at www.vuototecnica.net



SINGLE-STAGE VACUUM GENERATORS WITH EJECTOR 15 04 10

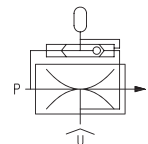
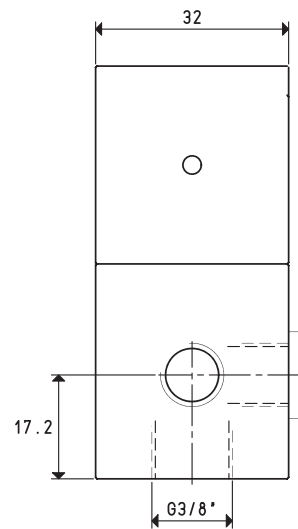
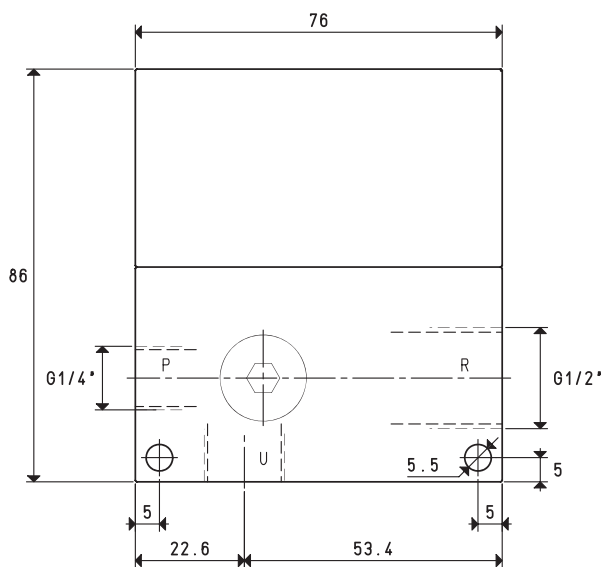

P=COMPRESSED AIR CONNECTION R=EXHAUST U=VACUUM CONNECTION

Art.	15 04 10			
Quantity of sucked air	cum/h	4.8	5	5
Max. vacuum level	-KPa	62	78	85
Final pressure	mbar abs.	380	220	150
Supply pressure	bar (g)	4	5	6
Air consumption	NI/s	1.3	1.6	1.8
Working temperature	°C	-20 / +80		
Noise level	dB(A)	79		
Weight	g	501		
Spare parts				
Sealing kit	art.	00 15 501		

Note: All the vacuum data indicated in the table are valid at the normal atmospheric pressure of 1013 mbar and are obtained with a constant supply pressure.

8.10

Conversion ratio: inch = $\frac{\text{mm}}{25.4}$; pounds = $\frac{\text{g}}{453.6} = \frac{\text{Kg}}{0.4536}$

GAS-NPT thread adapters available at page 1.117



8



SINGLE-STAGE VACUUM GENERATORS WITH EJECTOR 15 04 10

Air capacity (NI/s) at different vacuum levels (-KPa)

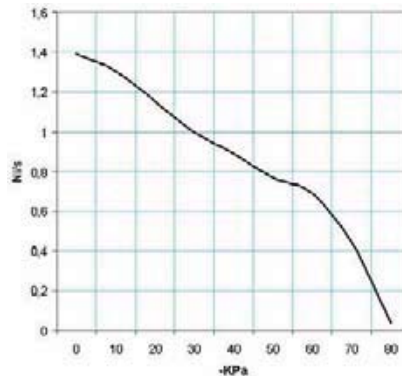

Generator art.	Supply press. bar (g)	Air consumption NI/s	Air capacity (NI/s) at different vacuum levels (-KPa)										Max. vacuum level -KPa
			0	10	20	30	40	50	60	70	80	85	
15 04 10	6.0	1.8	1.39	1.30	1.15	1.00	0.89	0.77	0.69	0.44	0.04	0.04	85

Evacuation time (ms/l=s/m³) at different vacuum levels (-KPa)

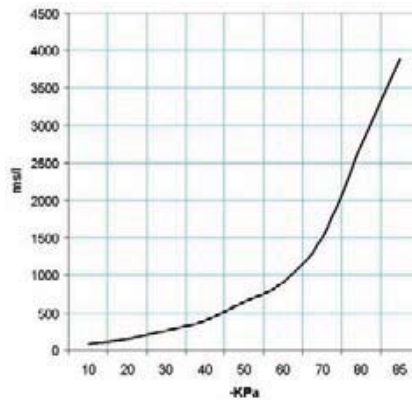

Generator art.	Supply press. bar (g)	Air consumption NI/s	Evacuation time (ms/l = s/m ³) at different vacuum levels (-KPa)										Max. vacuum level -KPa
			10	20	30	40	50	60	70	80	85		
15 04 10	6.0	1.8	77	154	261	403	649	902	1506	2730	3876	85	

Accessories upon request

Silencer art. SSX 1/2"

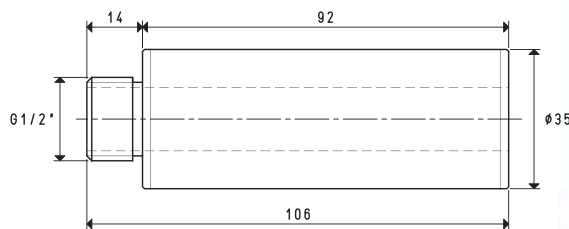

3D drawings available at www.vuototecnica.net

